



**Installation,  
Operation,  
Maintenance**

**Series DP**

**WE REDEFINE COMPRESSED AIR TREATMENT SYSTEMS**

---

## Contents

<b>1.</b>	<b>Introduction</b>	<b>3</b>
1.1	Design	3
1.2	Specifications	3
1.3	Description	3
1.4	Adsorbant Material	4
1.5	Operating Principles	4
1.6	Safety	4
<b>2.</b>	<b>Installation</b>	<b>5</b>
2.1	Storage	5
2.2	Installation site and connections	5
2.3	Electrical connections	6
2.4	Running the Installation	6
<b>3.</b>	<b>Operation</b>	<b>7</b>
3.1	Operator	7
3.2	Control panel	7
3.3	Operating cycle time	7
3.4	How to stop the dryer	8
<b>4.</b>	<b>Maintenance</b>	<b>8</b>
4.1	Changing the pre, oil and after filter element	9
4.2	Changing the desiccant	9
<b>5.</b>	<b>Changing the desiccant</b>	<b>9</b>
<b>6.</b>	<b>Repair work</b>	<b>10</b>
6.1	LEDs not glowing	
6.2	Tower status led not changing	
6.3	LEDs status changes but tower not switching	
6.4	No purging	
6.5	Continuous purging at tower 1	
6.6	High purge loss	
6.7	High pressure drop across dryer	
<b>7.</b>	<b>Commissioning Report</b>	

# INSTRUCTION MANUAL - DP Series

## READ THIS MANUAL CAREFULLY BEFORE INSTALLING OR OPERATING THE EQUIPMENT

 **These symbols warn you of any dangers and the measures to be taken to prevent them.**

The most important points for the correct operation of your dryer are printed in bold type.

### 1. Introduction

DP series is a heatless adsorption air dryer range especially made for higher compressed air flow treatment. Rigid and easy to maintain, each dryer is equipped with a pre-filter 25micron to protect the desiccant from the variety of air-compressed pollutant and with after filters to avoid fine desiccant powders at the outlet.

#### 1.1 Design

DP series heat-free regenerating adsorption dryers make it possible to eliminate any water vapour remaining in the compressed air at the outlet of the compressor + final condenser assembly. The dryers have been designed under nominal standard conditions in order to obtain a dew point at atmospheric pressure of - 40°C.

#### 1.2 Specifications

<b>Operational Data</b>		<b>Constructional Data</b>	
Inlet Air		Model	End Connections
Condition	: Free of dirt, oil and corrosive Substances	DP 72	¾" BSP
Temperature	: Max + 40°C	DP 96 to DP 288	1" BSP
Humidity	: Saturated at specified condition		
Outlet Air		DP 384	1½" BSP
Pre Filter rating	: 25 Microns	DP 480 to DP 960	2" NB ANSI B 16.5 Cl.150
After Filter rating	: 5 Microns		
Oil Adsorber rating	: 1 PPM	DP 1440 to DP 1920	3" NB ANSI B 16.5 Cl.150
Atm. Dew point	: Better than -40°C		
Control Voltage	: 230 VAC / 1Ø / 50 Hz		

### 1.3 Description

The dryer consists of :

- 2 Adsorbent towers filled with desiccant
- 1 Inlet valve or 2 Nos (above DP1440)
- 2 Exhaust valve
- 3 solenoid valves
- 2 exhaust silencers
- 1 regeneration nozzle
- 1 electronic control panel
- 3 Non return valve or 2 Non return valve (above DP960)
- 2 Pressure gauge
- 1 3/2 ball valve or 2 3/2 way (above DP 960)
- 1 Pre filter with drain valve
- 1 oil filter with drain valve
- 1 After filter

### 1.4 Adsorbant material

The desiccant takes the form of highly porous particles with surfaces, which are able to retain (adsorb) the water vapour present in the compressed air (drying phase) and restore it when the air is at atmospheric pressure (regeneration phase). The desiccant used is activated alumina ( $Al_2O_3$ ).

### 1.5 Operating Principle

- Moist Air from the compressor enters into the Pre filter through the inlet valve, water and oil coalesces here. The condensate is drained by Drain valve.
- Then it passes through the Oil filter, oil vapour condenses here. The condensate is drained by the Drain valve.
- In the drying tower, Alumina adsorbs the water vapour present in air and drops the dewpoint to lesser than  $-40^{\circ}C$ .
- Fine Alumina fines are removed in the After filter, rating 5 microns.
- Clean air is let out through the outlet port.

The two towers operate alternately in the drying and regeneration phases. Regeneration in one tower results from the expansion to atmospheric pressure of part of the compressed air in the other. Under nominal conditions (service pressure of 7 bar), 10% of the nominal flow is used for regeneration. The regeneration phase is shorter than the drying phase in order to allow the regenerated tower to return

to service pressure before a new cycle starts. The dryer is equipped with a two pressure gauge in each tower in order to measure the operating pressure of the tower.

### 1.6 Safety

 **Pressurised tanks may explode if used improperly. It is therefore essential to locate any equipment, which contains one or more of such tanks in such a way that the risks relating to incorrect use are reduced to the absolute minimum.**

The person responsible for the stuff who is going to install, operate and maintain the machines described in this manual must make sure that they have read and understood these instructions.

In particular we draw your attention to the safety procedures which are described in this manual and which must be scrupulously adhered to. Observing these measures will allow you to install, operate and maintain your dryer without risk.

DP Series dryers are intended for the drying of compressed air. Under no circumstances should they be used to dry other gases before Trident has performed a preliminary study and provided special instructions.

The desiccants used are not noxious. However, they may cause respiratory problems if they are inhaled in dust form. The use of a dust mask is sufficient to protect personnel. If dispersed in the environment, desiccants may represent a source of pollution the consequences of which are uncontrollable. By the end of its lifetime, the desiccant will have accumulated all the pollutants present in the compressed air. Use a non-polluting method of disposal.

## 2. Installation

 **Various risks (crushing, explosion, projection, noise,...) : The installation operations described in this chapter should be performed by personnel qualified in the installation of electro-pneumatic systems. Follow the procedure described below with care in order to prevent exposing personnel to danger.**

### 2.1 STORAGE

If your dryer is about to be stored during a long time before installation and use, take care to the following instructions :

- If possible let the dryer in its original packing (In particular products fitted with marine packing with plastic film and desiccant)

- Check that air inlet and outlet are correctly blocked in order to protect the desiccant against humidity and dust.
- Check that the machine is correctly protected from atmospheric dust or water.
- Check that the store is frost protected
- Make sure to archive correctly the attached documents.

## 2.2 Installation site and connections

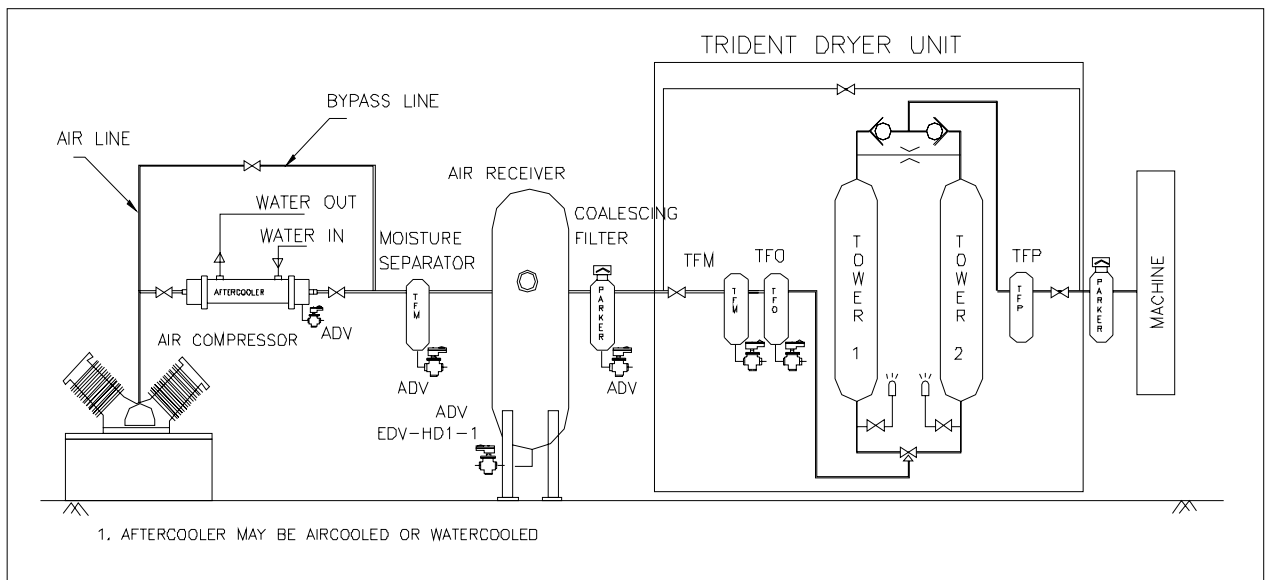

1. Install the dryer in a closed clean, dry room protected. Access to the room should be restricted to personnel qualified in unit maintenance and operation. The room must be adequately ventilated. The dryer must not be directly exposed to sources of heat. The temperature of the room must not exceed 43°C.
2. Make sure that the dryer is not near any equipment which does not comply with the electromagnetic compatibility directives and which may degrade dryer operation. There must be a minimum distance of 1 m between the dryer and any other equipment, which uses electricity.
3. Ensure that the dryer is installed in vertical position.
4. Fix the anchor points if it's necessary.
5. No bypass valve is required since the dryer itself is provided with the bypass system.
6. Connect the compressed air for processing to the dryer inlet (pre-filter connection) with strain-free ducts.

7. Connect the processed compressed air to the dryer output with strain-free ducts.
8. Check that all the connectors are airtight and that the fixings are tight.

### 2.3 Electrical connections

Connect the electrical power cable to a 220-240 V, single phase, 50 Hz grounded power supply. The electrical connecting is done by the DIN connector located on the front face of the dryer.



**Risk of electrical shock: When connecting the machine, cut off the power at the connecting point.**

### 2.4 Running the Installation



**Various risks (explosion, projection, noise, ...) : Do not pressurise until the installation procedure has been completed.**

The Bypass valve must be closed and the inlet air to be bypassed from the Dryer. Check the pressure in the tower and no deflection in the pressure gauge to be observed.

1. Switch on the Dryer and check the LED timings.
2. Open slowly the inlet 3/2 way valve and check the pressure on the dryer's pressure gauge.
3. Avoid any sudden variation in pressure as this may damage the dryer.
4. Slowly open the upstream valve and check the pressure at the dryer's pressure gauge.
5. Check the inlet flow and machine utilization and select the purge economizer.
6. Check the timings as per the chart given in 3.3 operating cycle time.

## 3.1 Operator

Only a minimum level of experience in handling compressed air is necessary to operate a Series DP dryer:

- Pressure in kg/cm<sup>2</sup> unit
- Flow in m<sup>3</sup> /hr unit
- Dew points in °C unit
- Components of a fluid network: compressor, valves, drains, taps, pressure gauges, filters, tanks

### 3.2 Control panel

The control panel presents all the instruments necessary to control and regulate the dryer (see appendix):

- A schematic diagram
- Two LEDs indicating the pre filter and oil filter drain operation (K).
- Six LEDs indicating the inlet and regeneration valve position and Tower status.
- Cycle failure indicator LED
- Purge Economiser selection LED.

### 3.3 Operating cycle time

- **Regeneration cycle** - occurs every 5 mins. During this cycle, air is depressurized in the tower. Sudden depressurisation brings the water molecules trapped in the desiccant pores to the surface. Dry air purged over the desiccant removes the water molecules.
- **Repressurising cycle** - To prevent Dryer from pressure spike, Regenerated tower is pressurized before it starts to drying cycle.
- **Purge Economiser** - It reduces the purge loss proportionate to the usage of compressed air. Select the Purge Economiser switch 40%, 60%, 80% or 100% according to air source delivery and usage. Select the nearest higher setting if the User percentage comes in between

Purge Economiser Vs Cycle time (Out of 5 mins)		
EcoNomiser	Regeneration	Repressurisation
40%	1 min 36 secs	3 min 24 secs
60%	2 min 24 secs	2 min 36 secs
80%	3 min 12 secs	1 min 48 secs
100%	4 min	1 min
Pre and Oil filter drain valves open at 9 min 30 secs for 4 secs		

- **Step Mode** - This mode helps for individual checking of exhaust and inlet flow valves. In the dip switch, switch 1 is kept in ON condition. When the data switch is selected, each valve energises, indicated by the corresponding LEDs in the display board.
- **Service mode** - This mode helps to test the Dryer in a short time. In the dip switch, switch 2 is kept in ON condition. Dryer's 10 min cycle time is changed into 1 min time. (Each tower drying 30 secs).
- After completing the Tests (Service & step mode) push back the Dip switch to all OFF condition.

## 3.4 How to stop the dryer

**!** **Various risks (projection, explosion, noise,...) : Whenever working on the dryer, it is essential to disconnect it from the network. Follow the procedure below:**

1. Change the inlet 3/2 way valve to Bypass position.
2. Leave the Dryer controller in switched on condition.
3. Ensure the 2 tower pressure gauges indicate 0 kg/cm<sup>2</sup> pressure.
4. **Switch off the controller.**

## 4. Maintenance

**Adsorption dryers are robust, reliable machines. To ensure uninterrupted, problem-free operation, regularly perform the inspections below.**

- Cycle functions normally.
- The silencers are not clogged.
- Drain valve functions proper.
- Regeneration is proper.
- Pressure drop across the dryer is not more than 0.3 kg/cm<sup>2</sup>
- Repeat the Daily, Monthly, Quarterly and Yearly Inspections periodically as per Table 2
- Apply Grease to the piston type Exhaust valves only

**Table 2**

Type of Inspection	LED	Drain Valve	Muffler	Filters			Inlet & Exhaust Valve	Desiccant	O rings, Gaskets
				Pre	Oil	After			
Timings	D	D	—	—	—	—	D	—	—
Function	—	D	—	—	—	—	D	—	—
Choke	—	—	Q	—	—	—	—	—	—
Replace	—	—	—	Y	H	Y	—	2Y or R	Y or R
Cleaning	1	Q	H	—	—	—	—	—	—
Quality check	—	—	—	—	—	—	—	2Y	Y

D - Daily    M - Monthly    Q - ¼ Yearly    H - ½ Yearly    Y - Yearly    2Y - Two yearly    R - As required

#### 4.1 Changing the Pre filter, Oil filter and after filter element.

 **Various risks (projection, noise, ...) : This operation should be performed by professionals of adsorption dryers. During the entire operation, the compressor and the dryer must be shut down. It is obligatory for all personnel who are in the presence of the desiccant to wear dust masks.**

1. Stop the dryer.
2. Loosen the Bolts and nuts of Filter housing
3. Remove the lock nut of solenoid coil in Drain valve assembly (for pre and oil filter only)
4. Remove the coil and remove the bottom housing without damaging the Drain valve
5. Unscrew the Filter element
6. Replace the old gasket with new one
7. Screw the new filter element, ensure that the joint is leak proof
8. Refit the bottom housing of the filter
9. Refit the drain valve assembly and solenoid coil (for pre and oil filter only)
10. Ensure the joints are leak proof
11. Start the machine

#### 4.2 Changing the Desiccant

 **Various risks (projection, noise, ...) : This operation should be performed by professionals of adsorption dryers. During the entire operation, the compressor and the dryer must be shut down. It is obligatory for all personnel who are in the presence of the desiccant to wear dust masks.**

1. Stop the Dryer
2. Remove the top desiccant inlet port-closing plug.
3. Remove the bottom port plug of one tower and collect the desiccant in the bin
4. Ensure there is no old desiccant in the tower
5. Similarly remove the desiccant from the other tower
6. Close the bottom ports with the plugs, ensure that there is no leakage
7. Fill the new desiccant through the top port
8. Refit the top plug, ensure there is no leakage through the plugs
9. To get the right quantity of desiccant for replacement, inform the Dryer model no and serial no to trident.

## INSTRUCTION MANUAL - DP Series

### 5. Recommended spares list for 2 years

Mechanical spares		Electrical spares	
a) Inlet Flow control valve spare kit	1	a) Controller PCB assembly	1
b) Tower 1 Exhaust valve	1	b) Transformer kit	1
c) Tower 2 Exhaust valve	1	c) Fuse pack	1
d) Non Return valve spare kit	1	d) Solenoid coil	1
e) Pre filter drain valve spare kit	1	e) Filter drain valve coil	1
f) Oil filter drain valve spare kit	1		
g) Oil Adsorber element	3		
h) Pre filter element	1		
i) After filter element	1		
j) Muffler	2		
k) Solenoid valve NO	1		
l) Solenoid valve NC	1		

### 6. Repair work

**The repair operations described in this section should be performed only by qualified persons in electro-pneumatic systems installation.**

Problem	Cause	Solution
1 No LED display in the controller	<ul style="list-style-type: none"> <li>● Fuse blown</li> <li>● PCB problem</li> </ul>	<ul style="list-style-type: none"> <li>● One of the coil may be shorting</li> <li>● Change Controller PCB</li> </ul>
2 Very high Purge Loss during Regeneration		
2.1 Tower 1	<ul style="list-style-type: none"> <li>● Inlet valve exhaust port may be choked</li> <li>● Plunger and Spring of Inlet valve solenoid valve may be damaged</li> <li>● Piston stuck in inlet valve</li> <li>● Tower 1 non return valve may not be closing properly</li> </ul>	<ul style="list-style-type: none"> <li>● Clean the choked port</li> <li>● Clean the damaged parts</li> <li>● Service valve or replace</li> <li>● Service valve or replace</li> </ul>

2.2 Tower 2	<ul style="list-style-type: none"> <li>● Power may not be coming to the inlet valve</li> <li>● Inlet valve Solenoid coil may be Open</li> <li>● Solenoid valve in/out ports may be choked</li> <li>● Tower 2 non return valve may not be closing properly</li> </ul>	<ul style="list-style-type: none"> <li>● Check controller, correct the loose connections.</li> <li>● Change the Solenoid coil</li> <li>● Clean the choked port</li> <li>● Service valve or replace</li> </ul>
3 During regeneration, pressure not coming to zero in corresponding tower	<ul style="list-style-type: none"> <li>● Muffler choke</li> <li>● Exhaust valve Din connection may be loose</li> <li>● Exhaust valve may be choked</li> <li>● Pressure gauge error</li> </ul>	<ul style="list-style-type: none"> <li>● Clean the Muffler</li> <li>● Correct the loose connection</li> <li>● Clean the Exhaust valve</li> <li>● Replace the gauge</li> </ul>
4 Continuous Air loss through Exhaust valve even after Controller in OFF condition		
4.1 For Diaphragm type exhaust valve	<ul style="list-style-type: none"> <li>● Solenoid valve in/out Port may be choked</li> <li>● Diaphragm may be damaged</li> </ul>	<ul style="list-style-type: none"> <li>● Clean the choked port</li> <li>● Change Diaphragm</li> </ul>
4.2 For Piston type exhaust valve	<ul style="list-style-type: none"> <li>● Solenoid valve-exhaust may be choked</li> <li>● Solenoid valve plunger or spring may be damaged</li> <li>● Exhaust valve piston stuck or poppet assembly damaged</li> </ul>	<ul style="list-style-type: none"> <li>● Clean the choked port</li> <li>● Service or replace the damaged parts</li> <li>● Service or replace the damaged parts</li> </ul>
5 Water at the outlet	<ul style="list-style-type: none"> <li>● Inlet/Bypass ball valve may be partially open in bypass/</li> <li>● Improper selection of purge economiser</li> </ul>	<ul style="list-style-type: none"> <li>● Open the valve completely in inlet position</li> <li>● Select Purge properly</li> </ul>

## INSTRUCTION MANUAL - DP Series

---

- Inlet air oil level may be more than 5 ppm or temperature may be very high (<50oC)
- Cycle may not be changing
- Muffler may be choked
- Exhaust may not take place during regeneration
- Drain valve does not function
- Place a Trident oil filter or pre cooler to control the oil level and temperature
- Change Controller
- Clean or change Muffler
- Service the valves
- Service the valves

### 6 Filter Drain valve always open

#### 6.1 For Piston type

- Piston stuck
- Core tube exhaust port may be choked
- Plunger spring or Main spring may be damaged
- Popper assembly or Poppet spring may be damaged
- Service the valve
- Clean the choked port
- Service or replace the damaged parts
- Service or replace the damaged parts

#### 6.2 For Strainer type

- Plunger spring or Main spring may be damaged
- Service or replace the damaged parts

### 7 Filter drain valve not opening

#### 7.1 For Piston type

- Pilot air nozzle may be choked
- Coil may be open
- Clean nozzle
- Replace coil

#### 7.2 For Strainer type

- Nozzle may be choked
  - Strainer may be choked
  - Coil may be open
  - Clean nozzle
  - Clean the choked parts
  - Replace coil
-

## P & I DIAGRAM DP 72 - DP 768

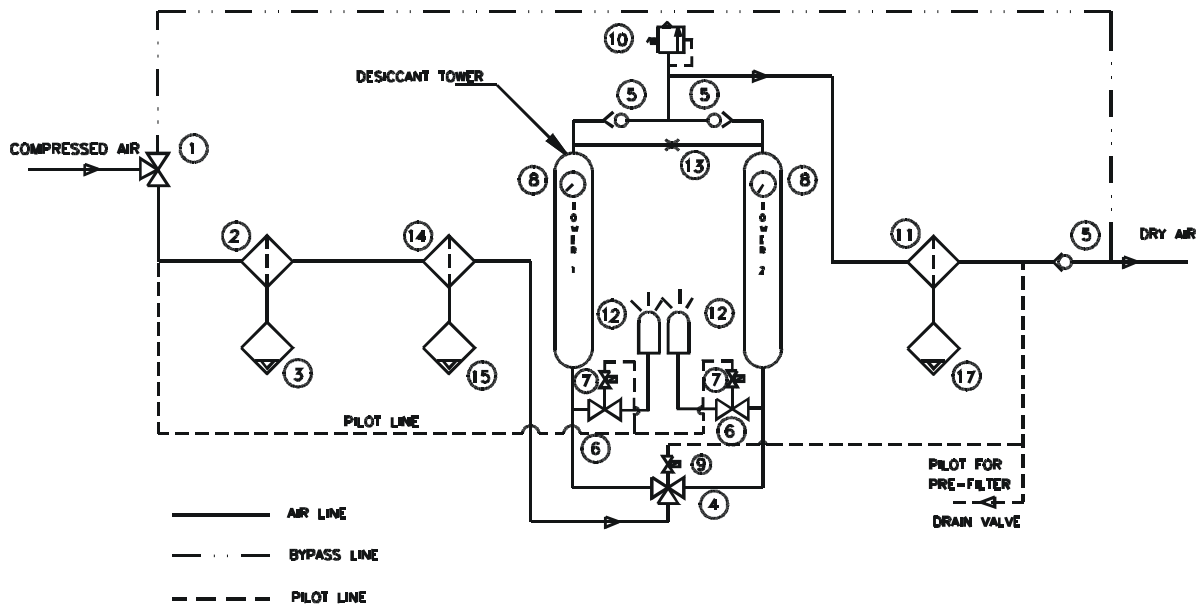

S.No.	MODEL	DWG. No.	PIPE SIZE
1.	DP 72	AD073	1"
2.	DP 96	AD071	1"
3.	DP 144	AD074	1"
4.	DP 192	AD075	1"
5.	DP 288	AD076	1"
6.	DP 384	AD072	1½"
7.	DP 480	AD077	2"
8.	DP 576	AD078	2"
9.	DP 768	AD505	2"

S.No.	DESCRIPTION	QTY/UNIT
1.	3/2 Way Ball Valve	1 No.
2.	Pre-Filter	1 No.
3.	Filter Drain Valve (Pre-Filter)	1 No.
4.	Inlet Flow Control Valve - 3/2 way	1 No.
5.	Non Return Valve	3 Nos.
6.	Exhaust Valve - 2/2 Way N/O	2 Nos.
7.	Solenoid Valve N/O	2 Nos.
8.	Pressure Gauge (0-21 Bar, 2-½" Dial)	2 Nos.
9.	Solenoid Valve N/O	1 No.
10.	Pressure Relief Valve	1 No.

S.No.	DESCRIPTION	QTY/UNIT
11.	After Filter	1 No.
12.	Muffler	2 Nos.
13.	Regeneration Nozzle	1 No.
14.	Oil Filter	1 No.
15.	Filter Drain Valve (Oil filter)	1 No.
16.	Controller (Not shown)	1 No.
17.	Filter Drain Valve (After filter)	1 No.

# INSTRUCTION MANUAL - DP Series

## P & I DIAGRAM DP 960

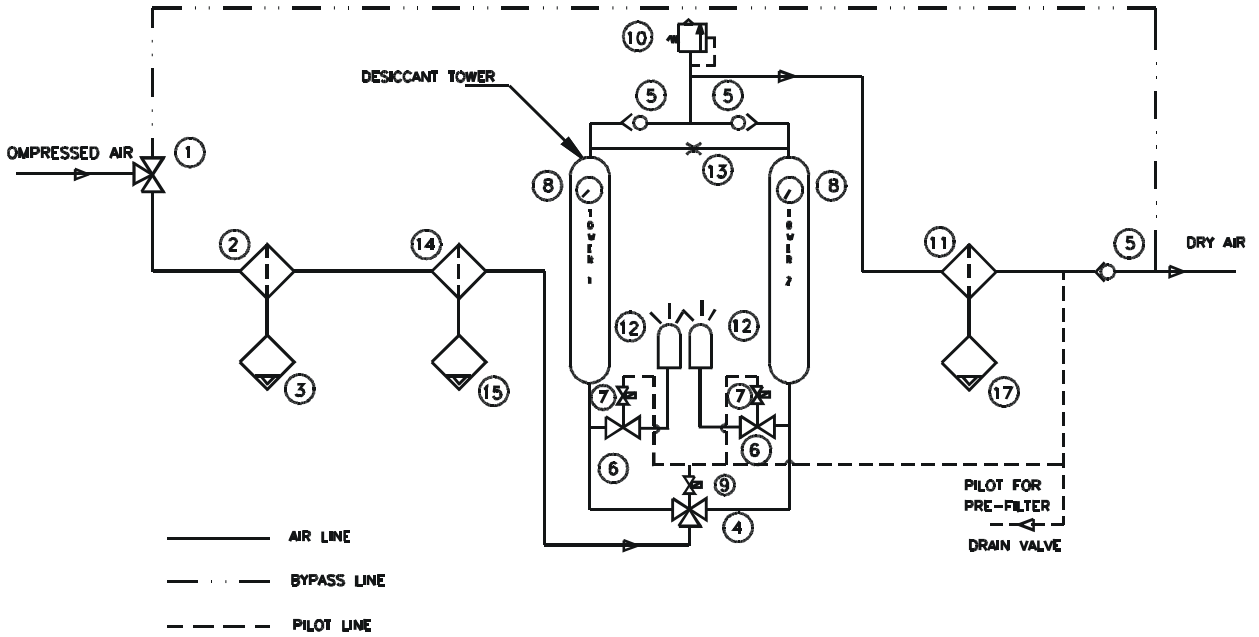

S.No.	DESCRIPTION	QTY/UNIT
1.	3/2 Way Ball Valve	1 No.
2.	Pre-Filter	1 No.
3.	Filter Drain Valve (Pre-Filter)	1 No.
4.	Inlet Flow Control Valve - 3/2 Way	1 No.
5.	Non Return Valve	3 Nos.
6.	Exhaust Valve - 2/2 way N/O	2 Nos.
7.	Solenoid Valve N/O	2 Nos.
8.	Pressure Gauge (0-21Bar, 2-½" Dial)	2 Nos.
9.	Solenoid Valve N/O	1 No.
10.	Pressure Relief Valve	1 No.

S.No.	DESCRIPTION	QTY/UNIT
11.	After Filter	1 No.
12.	Muffer	2 Nos.
13.	Regeneration Nozzle	1 No.
14.	Oil Filter	1 No.
15.	Filter Drain Valve (Oil filter)	1 No.
16.	Controller (Not shown)	1 No.
17.	Filter Drain Valve (After filter)	1 No.

## P & I DIAGRAM DP 1440 - DP 1920

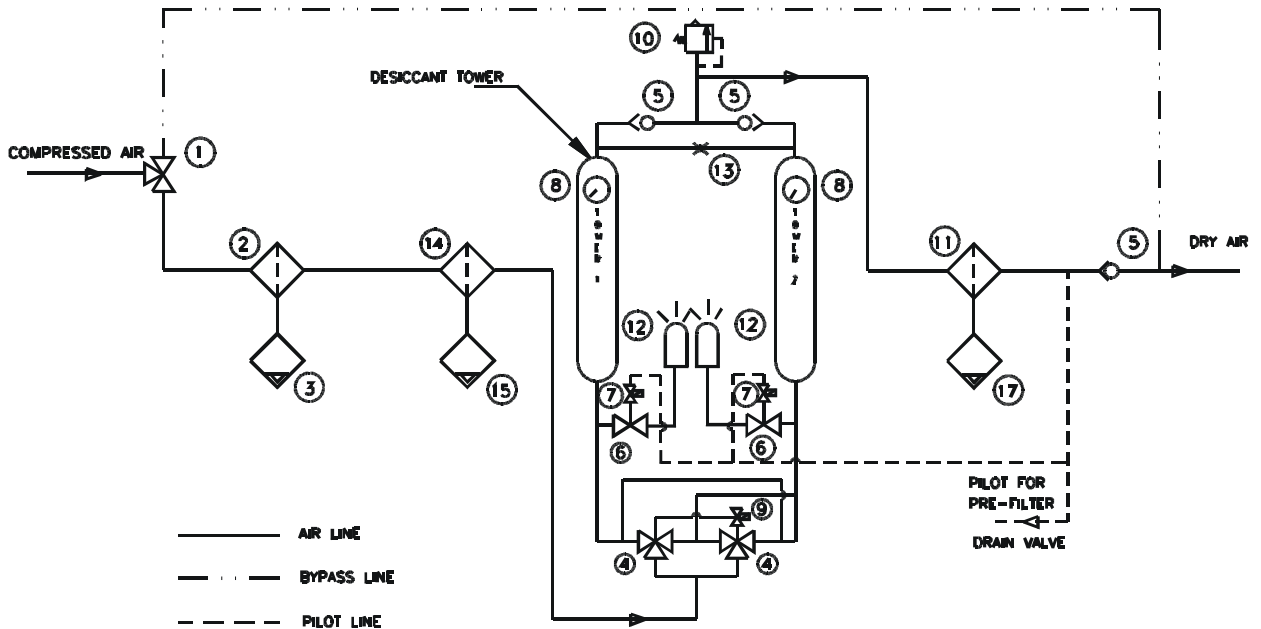

S.No.	DESCRIPTION	QTY/UNIT
1.	3/2 Way Ball Valve	1 No.
2.	Pre-Filter	1 No.
3.	Filter Drain Valve (Pre-Filter)	1 No.
4.	Inlet Flow Control Valve - 3/2 Way	1 No.
5.	Non Return Valve	3 Nos.
6.	Exhaust Valve - 2/2 way N/O	2 Nos.
7.	Solenoid Valve N/O	2 Nos.
8.	Pressure Gauge (0-21Bar, 2-1/2" Dial)	2 Nos.
9.	Solenoid Valve N/O	1 No.
10.	Pressure Relief Valve	1 No.

S.No.	DESCRIPTION	QTY/UNIT
11.	After Filter	1 No.
12.	Muffler	2 Nos.
13.	Regeneration Nozzle	1 No.
14.	Oil Filter	1 No.
15.	Filter Drain Valve (Oil filter)	1 No.
16.	Controller (Not shown)	1 No.
17.	Filter Drain Valve (After filter)	1 No.

# INSTRUCTION MANUAL - DP Series

## WIRING DIAGRAM

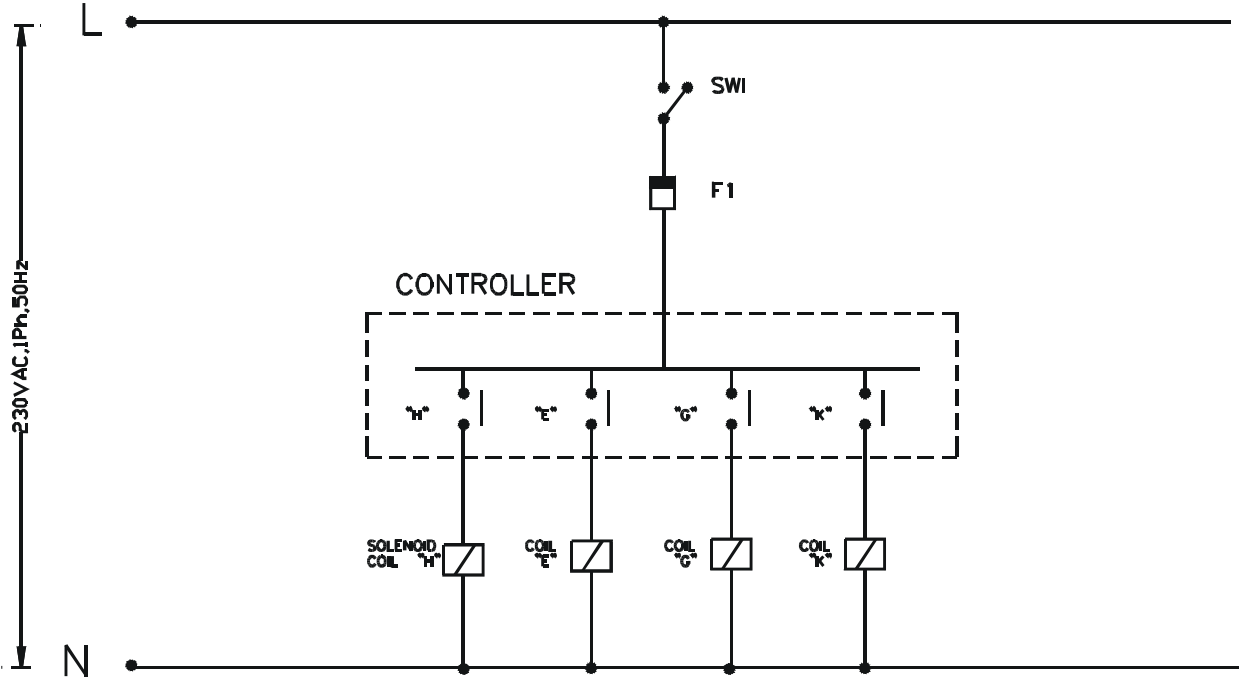

S. No.	DESCRIPTION	TAG. No.	MAKE
1.	POWER ON/OFF SWITCH	SW-1	ELCOM/EQ.
2.	GLASS FUSE, 2 Amps, $\phi 5$	F1	ELCOM/EQ.
3.	SOLENOID COIL	H, E, G, K	TRIDENT/JANATICS/EQ.
4.	CONTROLLER	—	TRIDENT

## CONTROLLER SCHEMATIC LAYOUT

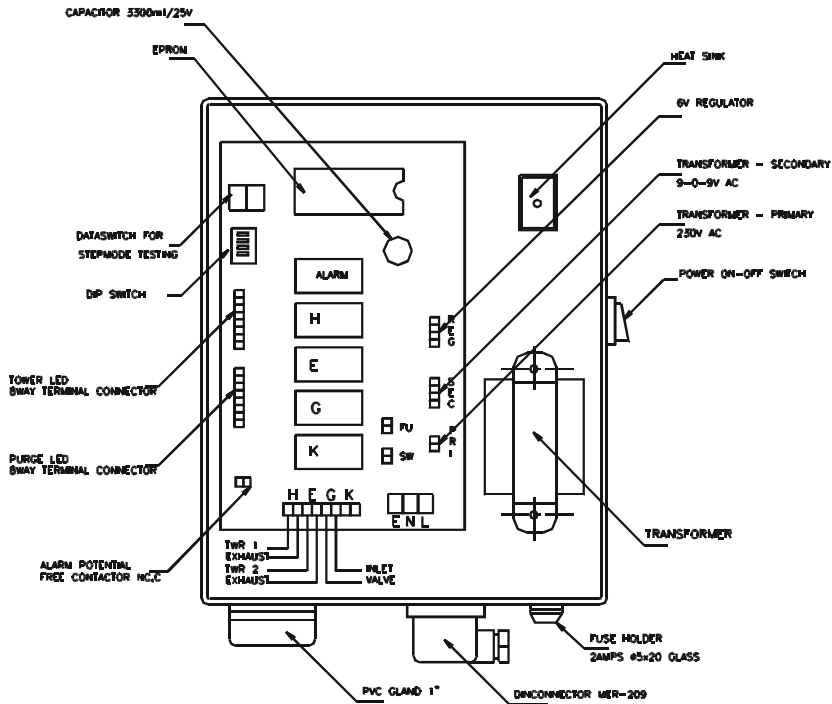

### MIMIC DISPLAY

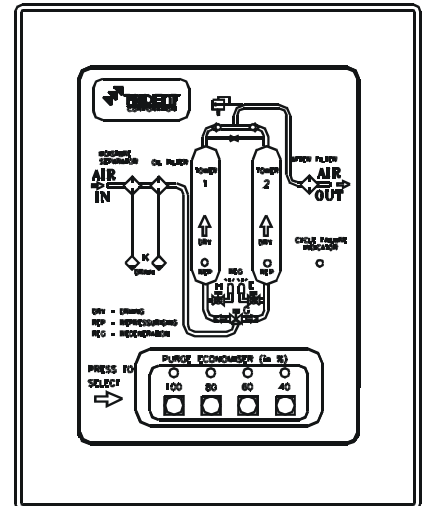

TOLERANCE CLASS	GENERAL TOLERANCE FOR LINEAR DIMENSIONS IS2102-1993						
DESCRIPTION	0.5-6	7-30	31-120	121-400	401-1000	1001-2000	2001-4000
MEDIUM	+0.1	+0.2	+0.3	+0.5	+0.8	+1.2	+2

# INSTRUCTION MANUAL - DP Series

## INLET FLOW CONTROL VALVE

Sizes in mm

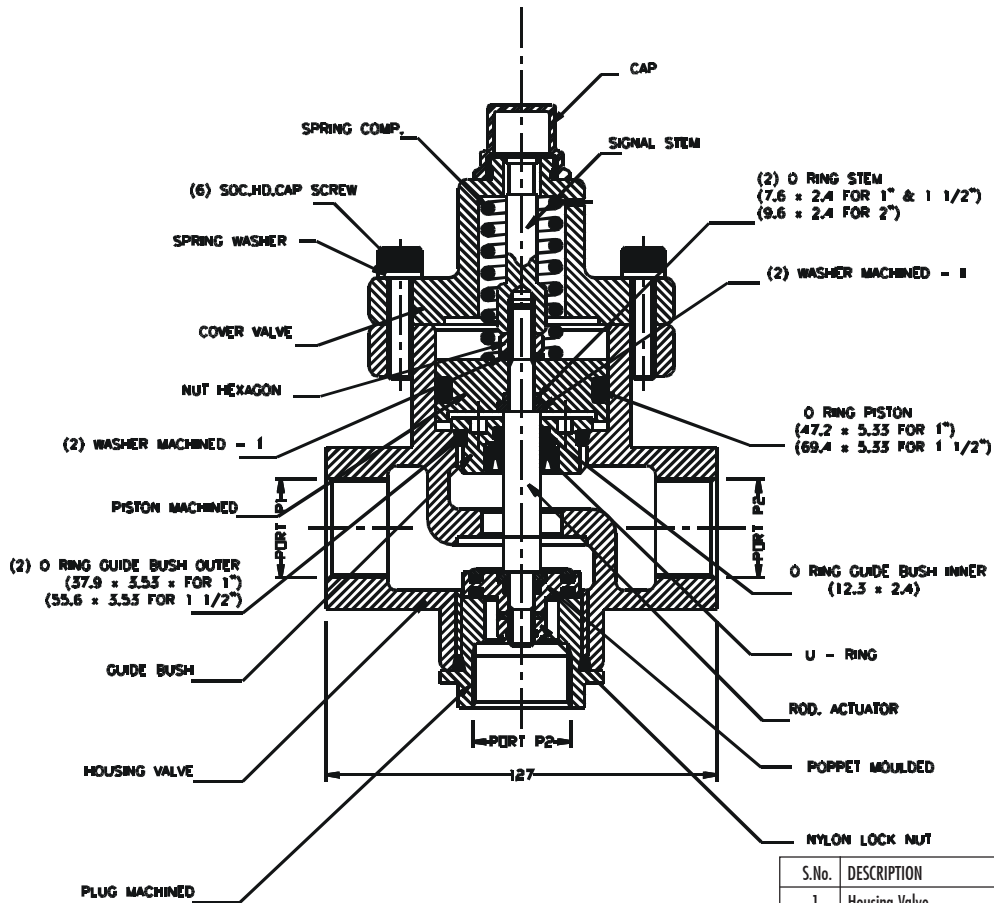

S.No.	DESCRIPTION	Drg. No.
1.	Housing Valve	32014
2.	Plug Machined	31785
3.	Rod Actuating	32027
4.	Cover Valve	32023
5.	Piston Machined	32022
6.	Guide Bush	32024
7.	Washer Machined - I	32025
8.	Washer Machined - II	32025
9.	Poppet Moulded	31788
10.	Spring Comp.	31815
11.	O Ring Piston	31513
12.	O Ring Guide Bush Outer	31546
13.	O Ring Stem	31790
14.	O Ring Guide Bush Inner	31540
15.	U Ring	31488
16.	Signal Stem	32026
17.	Cap	31869
18.	Soc. HD. Cap Screw	30055 (M10x35)
19.	Spring Washer	30006 (M10)
20.	Nut Hexagon	30021 (M10)
21.	Nylon Lock Nut	30054 (M10)

## TOWER EXHAUST VALVE - NC

Sizes in mm

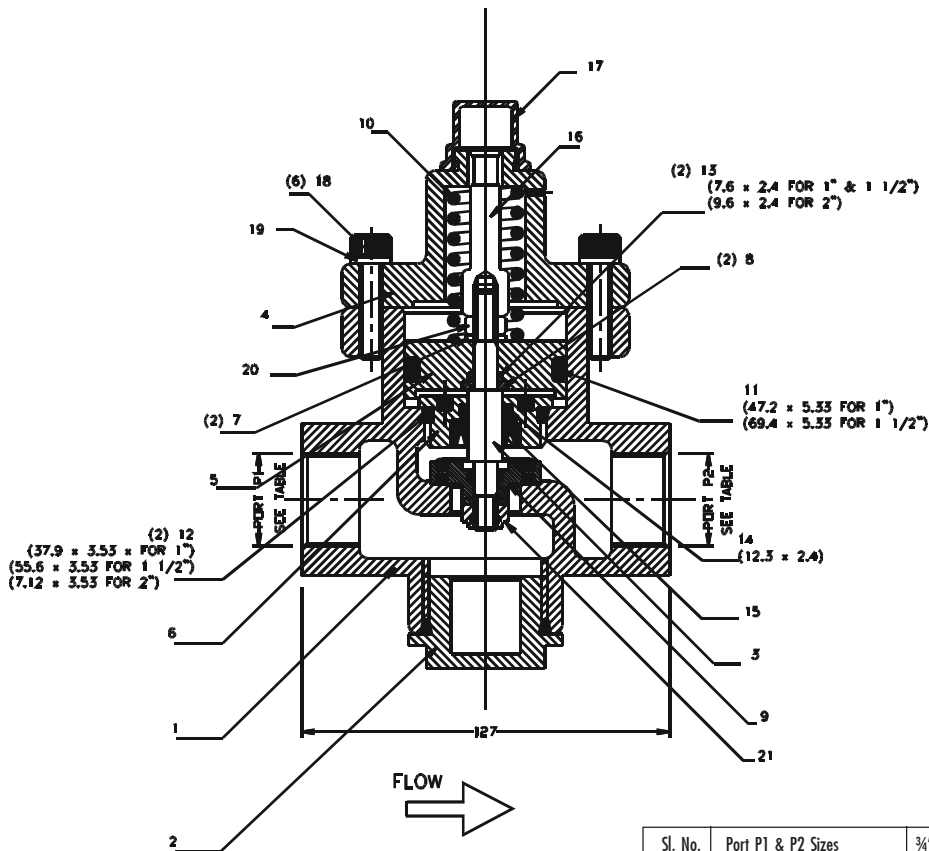

Sl. No.	Port P1 & P2 Sizes	3/4" BSP	1" BSP	1 1/2" BSP	2" BSP
	Assy. Blow Down Valve	32033	32036	32037	32038
1.	Housing Valve	32011	32012	32013	32014
2.	Plug Machined	32039	31663	31663	31785
3.	Rod Actuating	32010	32020	32020	32027
4.	Cover Valve	32003	32017	32017	32023
5.	Piston Machined	32002	31661	31661	32022
6.	Guide Bush	32004	32018	32018	32024
7.	Washer Machined - I	31974	31974	31974	32025
8.	Washer Machined - II	32005	32005	32005	32025
9.	Poppet Moulded	32007	31666	31666	31788
10.	Spring Comp.	31808	31810	31810	31815
11.	O Ring Piston	31604	31643	31643	31513
12.	O Ring Guide Bush Outer	31044	31066	31066	31546
13.	O Ring Piston Small End	31623	31623	31623	31790
14.	O Ring Guide Bush Inner	31540	31540	31540	31540
15.	U Ring	31488	31488	31488	31488
16.	Signal Stem	32008	32019	32019	32026
17.	Cap	31869	31869	31869	31869
18.	Soc. HD. Cap Screw	30055 (M8x35)	30055 (M10x35)	30055 (M10x35)	30055 (M10x35)
19.	Spring Washer	30003 (M8)	30006 (M10)	30006 (M10)	30006 (M10)
20.	Nut Hexagon	30019 (M8)	30019 (M8)	30019 (M8)	30021 (M10)
21.	Nylon Lock Nut	30053 (M8)	30053 (M8)	30053 (M8)	30054 (M10)

# INSTRUCTION MANUAL - DP Series

## TOWER EXHAUST VALVE - NO

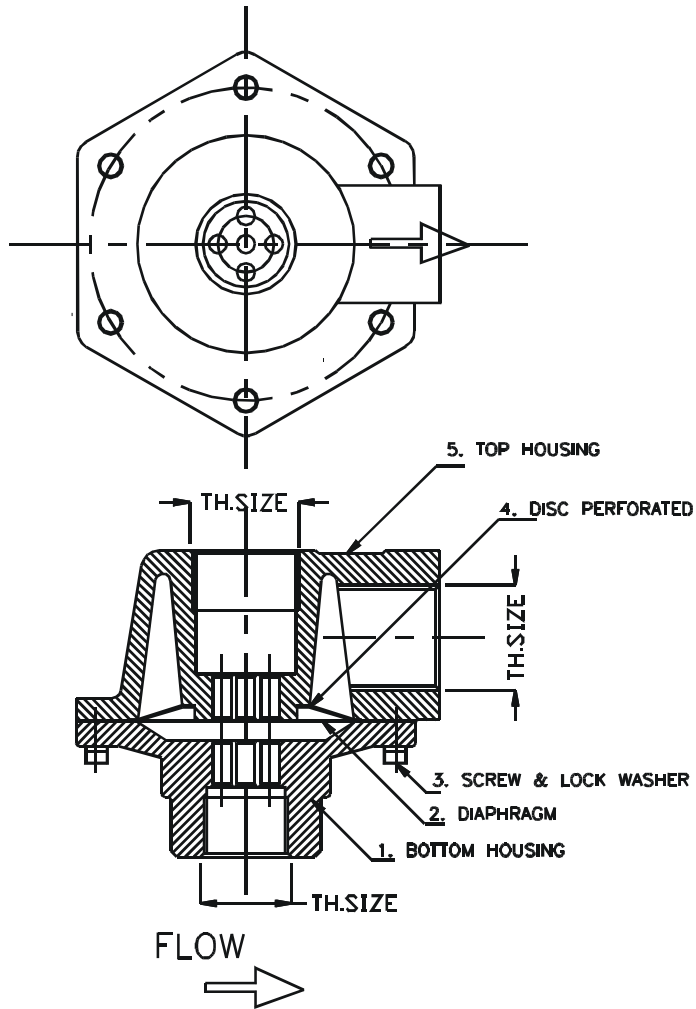

Sl. No.	DESCRIPTION	THREAD SIZE	ORDERING CODE				
			1	2	3	4	5
1.	24 - 72	½" BSP	31683	31679	30037	31678	31681
2.	96 - 144	¾" BSP	31694	31689	30038	31692	31692
3.	192 - 384	1" BSP	31698	31701	30039	31700	31696
4.	480 - 1920	1" BSP	31698	31701	30039	31700	31696

## FILTER DRAIN VALVE

Sizes in mm

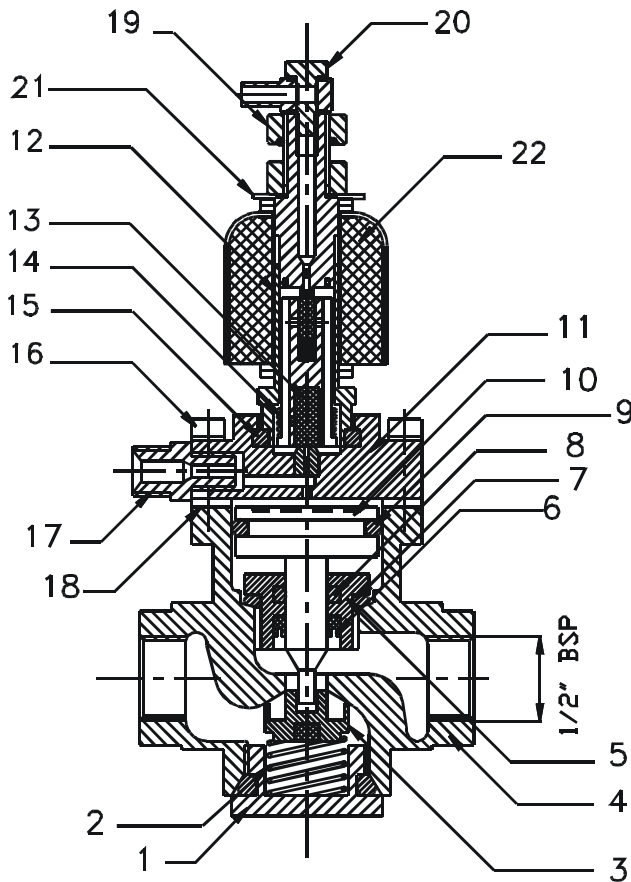

Sl. No.	DESCRIPTION	QTY	MATERIAL
1.	Lock Nut	1 No.	Brass
2.	Poppet Springq	1 No.	P. Bronze
3.	Poppet	1 No.	Brass
4.	HD Valve Body - I	1 No.	Aluminium
5.	Brass Insert	1 No.	Brass
6.	Wiping Seal	1 No.	N. Rubber
7.	Insert O Ring	1 No.	N. Rubber
8.	Piston O Ring Small	1 No.	N. Rubber
9.	Piston O Ring Big	1 No.	N. Rubber
10.	Piston	1 No.	Aluminium
11.	Adaptor Plate	1 No.	Aluminium
12.	Coretube Subassy - HD	1 No.	Various
13.	Plunger - HD	1 No.	SS 410
14.	Spring Main - HD	1 No.	P. Bronze
15.	O Ring Solenoid	1 No.	N. Rubber
16.	M 6 x 25 Allen Bolts	1 No.	Steel
17.	1/4" - 1/8" BSP Connector	1 No.	Brass
18.	Gasket	1 No.	CAF
19.	M10x1.25 Retaining Nut - HD	1 No.	M.S.
20.	Vent Connector Assy	1 No.	Various
21.	14mm Spacer	2 Nos.	M.S.
22.	Solenoid Coil	1 No.	Various

**NOTE :**

1. PRE-FILTER DRAIN VALVE : MODEL DP 192 and above.
2. OIL FILTER DRAIN VALVE : MODEL DP 960 and above-

# INSTRUCTION MANUAL - DP Series

## FILTER DRAIN VALVE

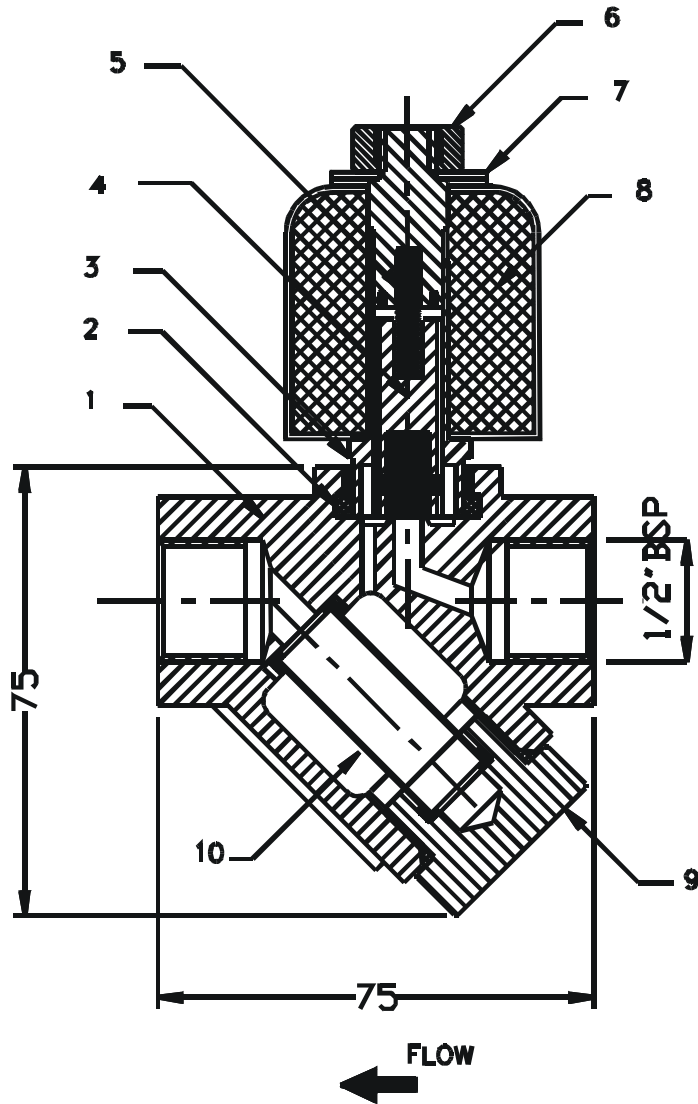

Sizes in mm

**NOTE :**

- 1. PRE-FILTER DRAIN VALVE : MODEL DP 72 - 144
- 2. OIL FILTER DRAIN VALVE : MODEL DP 72 - 768

Sl. No.	DESCRIPTION	QTY	MATERIAL
1.	Valvebody EDV 1 (M/c ing)	1 No.	Various
2.	O Ring Solenoid	1 No.	N. Rubber
3.	Coretube Subassy - Reg	1 No.	Various
4.	Plunger Assy - Reg	1 No.	Various
5.	Spring Main - Reg	1 No.	SS
6.	M10 x 1.25 Retaining Nut	1 No.	M.S.
7.	14mm Spacer	1 No.	M.S.
8.	Solenoid Coil with Cup	1 No.	Various
9.	Drain Plug Assy	1 No.	Various
10.	Strainer Assy - Y	1 No.	Various

# WARRANTY

Products of Trident Pneumatics Pvt Ltd are guaranteed to be free from defects in materials and workmanship when installed and operated in accordance with the instructions outlined in the Instruction Manual.

Trident Pneumatics Pvt. Ltd.'s obligation under this warranty shall be limited to repair or replacement (at the discretion of Trident) of defective goods returned to Trident's plant within one (1) year from the date of commissioning.

Product	:
Model	:
Serial No.	:
	:

---

Quality Assurance Dept.

## **Trident Pneumatics Pvt Ltd**

5/232, K.N.G Pudur Road, Somayampalayam,  
Coimbatore 641 108. Ph : 0422 2400492, 2401373  
Fax : 0422 2401376 e-mail : sales@tridentpneumatics.com  
Website : www.tridentpneumatics.com

# INSTALLATION & COMMISSIONING REPORT

## HEATLESS DESICCANT DRYER

Customer :	Model :
Contact person :	Sl.No :
Designation :	Phone :
	Fax :

(Please add any comments or remarks here found while unpacking)

### 1. INSTALLATION

a) Installation at : Before / After Air Receiver	LED Glowing	Yes / No
b) Inlet Air Temperature : Normal / High	Tower 1 and 2 Drying	Yes / No
c) Side clearance provided : Yes / No	Depressurizing	Yes / No
d) Power Grounded : Yes / No	Regeneration	Yes / No
e) Air Flow Outlet : Normal / Faulty	Purge Economiser 40% / 60% / 80% / 100%	Yes / No
f) Change over sequence : Normal / Faulty	Filter Drain Valves	Yes / No
g) Change over sequence : Normal / Faulty		

### 2. COMMISSIONING

Installation	Date of completion
Commissioning	Date of completion

Comments :

Customer	Installation Engineer
----------	-----------------------

_____ Signature & Name of installing Engineer	_____ Dealers Signature & Seal	_____ Customer's Signature & Seal
---	--------------------------------------	---

# INSTALLATION & COMMISSIONING REPORT

## HEATLESS DESICCANT DRYER

Customer :	Model :
Contact person :	Sl.No :
Designation :	Phone :
	Fax :

(Please add any comments or remarks here found while unpacking)

### 1. INSTALLATION

a) Installation at : Before / After Air Receiver	LED Glowing	Yes / No
b) Inlet Air Temperature : Normal / High	Tower 1 and 2 Drying	Yes / No
c) Side clearance provided : Yes / No	Depressurizing	Yes / No
d) Power Grounded : Yes / No	Regeneration	Yes / No
e) Air Flow Outlet : Normal / Faulty	Purge Economiser 40% / 60% / 80% / 100%	Yes / No
f) Change over sequence : Normal / Faulty	Filter Drain Valves	Yes / No
g) Change over sequence : Normal / Faulty		

### 2. COMMISSIONING

Installation	Date of completion
Commissioning	Date of completion

Comments :

Customer	Installation Engineer
----------	-----------------------

_____ Signature & Name of installing Engineer	_____ Dealers Signature & Seal	_____ Customer's Signature & Seal
---	--------------------------------------	---

## **TRIDENT PNEUMATICS PVT LTD**

5/232, K.N.G. Pudur Road, Somaiyampalayam P.O.,  
Coimbatore - 641 108, India. Ph : +91-422-2400492 Fax : +91-422-2401376  
e-mail : [sales@tridentpneumatics.com](mailto:sales@tridentpneumatics.com) Website : [www.tridentpneumatics.com](http://www.tridentpneumatics.com)