

Lasting Values

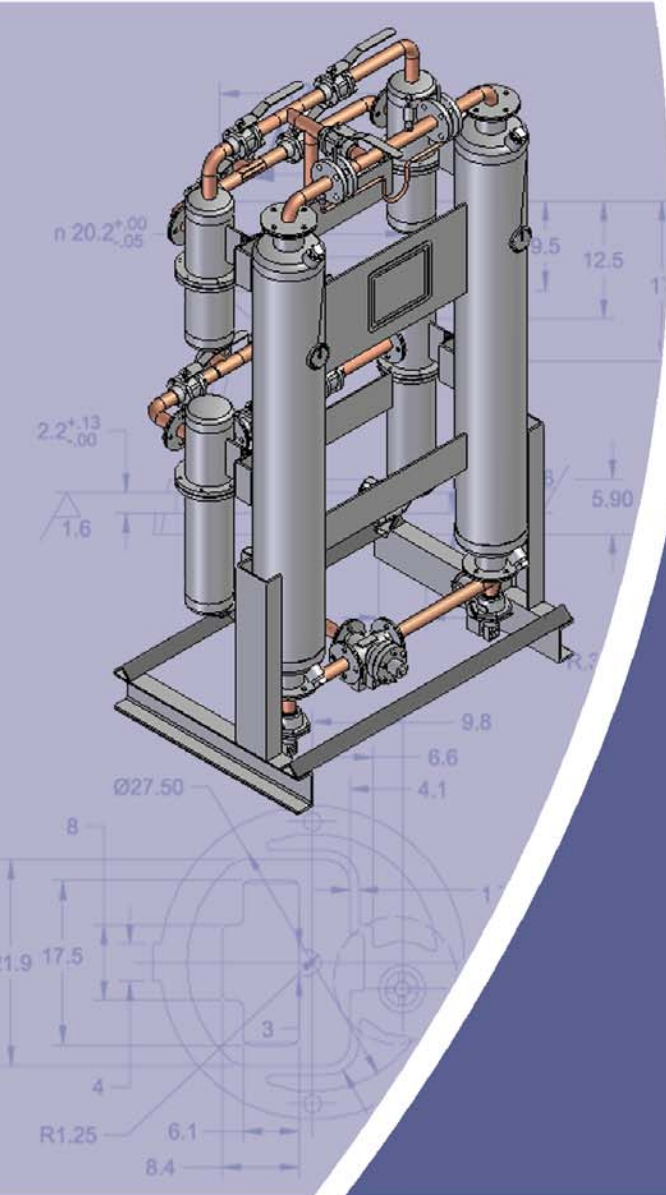

Compressed Air Dryers (Heatless)

DP Series

- Extensive Mimic display with Electronic Controller
- Energy saving purge economiser
- Stainless Steel Filters Cartridges
- Fabrication Code : IS 2825
- Dewpoint better than -40° C

Optional :

- Fabrication Code : ASME SEC VIII DIV I
- Dewpoint based changeover



India's Largest Exporter of Compressed Air Treatment Products

Highlights

Purge Economiser : By setting a switch in the controller at a percentage of maximum flow, the controller will close the purge valve when sufficient purge air has been used. This reduces purge loss according to air usage. The purge loss, which is 14% normally reduces to as low as 5.6%.

No pressure spike : During changeovers ensures long desiccant life.

Selection Example

Requirement :

Flow Volume : 175 cfm
 Working Pressure : 6 Kg / cm²
 Inlet air Temperature : 45°C
 Referring the Graphs : Factor (T) = 0.9
 Factor (P) = 0.88

Dryer capacity required :

$$\frac{\text{Flow volume}}{\text{Factor (T) x Factor (P)}} = \frac{175}{0.9 \times 0.88} = 220.9 \text{ cfm}$$

Choose the nearest higher model i.e, Model DP 384

Specification

Model	Inlet Flow cfm	End Connection	Dimensions (mm)			Weight Kg
			Height	Width	Depth	
DP - 192	114	1" BSP	2000	750	650	380
DP - 288	172	1" BSP	2050	750	650	440
DP - 384	229	1½" BSP	2100	750	650	550
DP - 480	286	2" NB	1640	1200	1300	620
DP - 576	343	2" NB	1975	1200	1300	700
DP - 768	458	2" NB	1860	1200	1300	850
DP - 960	572	2" NB	2200	1200	1300	950
DP - 1440	860	3" NB	1925	1500	1500	1265
DP - 1920	1144	3" NB	2350	1500	1500	1575

- Operating voltage - 230 V AC 50 Hz 1 Ph.
- For any other capacity contact factory.
- Specifications are subject to change without notification.

Principle of Operation

Pre-filtration : The moisture laden compressed air passes through the pre filter, here moisture load is reduced through coalescence. Condensation is removed through the drain valve ADV1. At the oil filter oil vapours are removed completely, small level of water condensation is purged through the valve ADV2.

Drying : (Please refer figure) The Towers are filled with Activated Alumina as desiccant (Molecular sieve available as option). When air passes through Tower 1 which consists of "DRY" Desiccant, it gets completely dried, and passes through check valve and after filter. At the after filter, Desiccant fines are removed. Therefore dry compressed air passes out at the outlet.

Regeneration : (Please refer figure) Regeneration takes place in 2 stages a) De-pressurisation b) By passing Dry air. Tower II consists of fully moist desiccant at pressure. This is suddenly De-pressurised by opening the purge valve. Water molecules seep out of the desiccant and appear on the surface. "Super Dry" purge air passes through the Regeneration "Nozzle" and the desiccant bed thereby completely carrying away the water molecules. Tower II gets regenerated and is ready for the next drying cycle after the re-pressurisation.

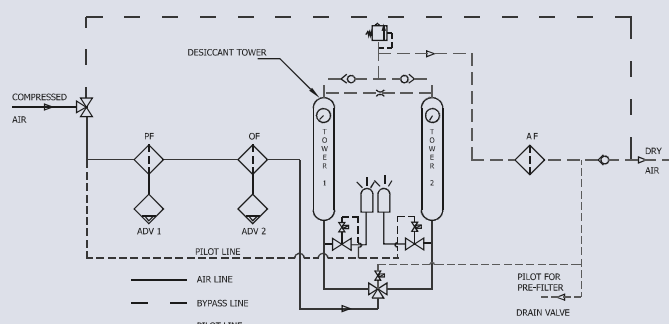

Inlet Temperature Correction Factor

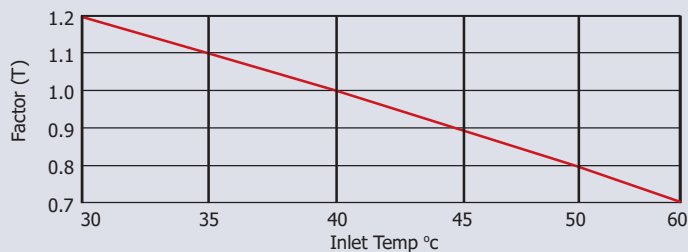

Inlet Pressure Correction Factor

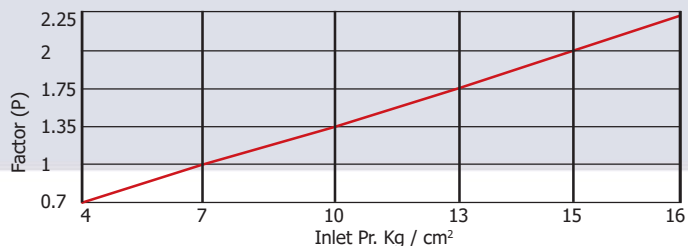

Our Other Range of Products

- Timer based Auto Drain Valve
- Level Sensing Auto Drain Valve
- Desiccant Dryer (Heated)
- Refrigeration Dryers
- Moisture Separator
- Submicron Filter



Trident Pneumatics Pvt Ltd

5/232, K.N.G. Pudur Road, Coimbatore - 641 108, India.
 Ph : +91-422-2400492 Fax : +91-422-2401376

Trident Pneumatics Pvt Ltd

Shanghai, China.

Trident Pneumatics Sdn Bhd

Selangor, Malaysia.

e-mail : sales@tridentpneumatics.com Website : www.tridentpneumatics.com

Sales & Service Outlets

Ahmedabad	Baroda	Bangalore	Chennai	Delhi	Hyderabad	Kolkatta	Mumbai	Pune
98259 26342	98795 16299	98450 93322	98400 97782	98113 10726	98854 45321	24599155	25434551	27471877